

Wheel Bearings & Wheel Seals



Wheel Seals

Power10 Seals are engineered for superior performance.

The new Power10 heavy duty wheel seals deliver significant energy savings and increase the reliability and durability performance expectations for wheel seals in the heavy duty truck and trailer industry.

Power10 Seals' design incorporates proprietary materials,

advance main lip design geometry, and an integrated polished wear sleeve for the seal to run on. This advanced combination results in low-torque performance while not sacrificing contaminant exclusion, resulting in an industry leading 500,000+ mile long seal life.

Power10 Seals' low-friction torque design offers potential fuel

savings of \$1,300-\$2,100* per tractor/trailer combo over a potential warrantable life of 350,000 miles, due to 50% less operating torque than competitors' seals. Power10 seals include a patented "dirt exclusion fin" that assists in keeping contamination away from the seal and leads to increased seal durability and performance life.

*Fuel savings based on diesel fuel at current \$4.00/gal. and based on 10 wheel end positions.

VALUES TO THE CUSTOMER

- Proprietary design lowers torque leading to lower internal heat generation, excellent wear resistance, and improved fuel economy
- Higher operating temperatures (up to 176.7°C/350°F)
- Compatible with mineral and synthetic oils, and grease lubricants
- Superior protection against contaminants with "Fin Feature" and additional contaminant exclusion lip increasing performance and seal life
- Lubed ID design seals minor hub or spindle imperfections

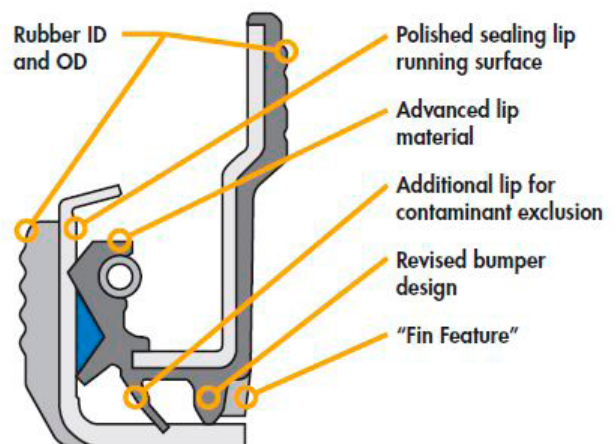

For more information visit www.theuniversalgroup.com or call 1.800.225.1845

Universal Group[®]



The Universal Group, LLC
1025 Thomas Busch Memorial Highway
Pennsauken, New Jersey 08110
1.800.225.1845
856.488.1800
Fax 1.800.360.9636

Wheel Bearings & Wheel Seals

Wheel Bearings

Power10 Bearings add to our wheel end line to keep your trucks on the road.

Our **Power10 Bearings** are manufactured by an OE supplier complying to the ANSI/ABMA 19.2 standard.

Power10 Bearings are sold as a cup and cone set.

Initial inventory of wheel bearings compliments our newly introduced wheel seals. Our bearings and wheel seals catalog will continue to grow as we add more applications.

Our bearing standards are conforming to ANSI/ABMA Standard 19.2 and Material Specifications ASTM A295/A295M-2014.



Application	Power10 Parts® Part Number	Bearings Inner Cone/Cup	Bearings Outer Cone/Cup
Steer Axle, 12K# Dana Spicer, Eaton, Rockwell, Ford, Freightliner & Sterling, Kenworth, Mack, Navistar, Peterbilt, Volvo, Western Star	SWS-35059	SWB-413	SWB-406
	<u>Cross Reference</u>	<u>Cross Reference</u>	<u>Cross Reference</u>
	35058	HM212049/HM212011	3782/3720
	35059		
	380001A		
Drive Axle, 38K# Tandem, Dana Spicer, Eaton, Rockwell, Ford, Freightliner & Sterling, Kenworth, Mack, Navistar, Peterbilt, Volvo, Western Star	SWS-47695	SWB-403	SWB-401
	<u>Cross Reference</u>	<u>Cross Reference</u>	<u>Cross Reference</u>
	47695	594A/592A	580/572
	47691		
	47692		
	380003A		
	393-0173		
	393-0273		